

DH-PFB110W

Wall Mount Bracket



Features

- Aesthetic design
- Wall mount/plane mount/ceiling mount bracket
- Material: aluminum

Technical Specifications

| | |
|-----------------------|----------------------------------|
| Model | DH-PFB110W |
| General | |
| Material | Aluminum |
| Dimension | φ95mmx194.2mm (φ3.74"x7.64") |
| Pipe Thread | 1/4"-20 UNC |
| Weight | 0.18kg(0.4lb) |
| Load Bearing | 1kg(2.2lb) |
| Color | White |
| Operating Temperature | -40°C~+60°C(-40°F~+140°F) |
| Humidity | <90% RH |
| Applicable Model | Please see "Accessory Selection" |

Order Information

| Type | Part Number | Description |
|--------------|-------------|--------------------|
| Camera Mount | DH-PFB110W | Wall mount bracket |
| | PFB110W | Wall mount bracket |

Dimensions (mm/inch)

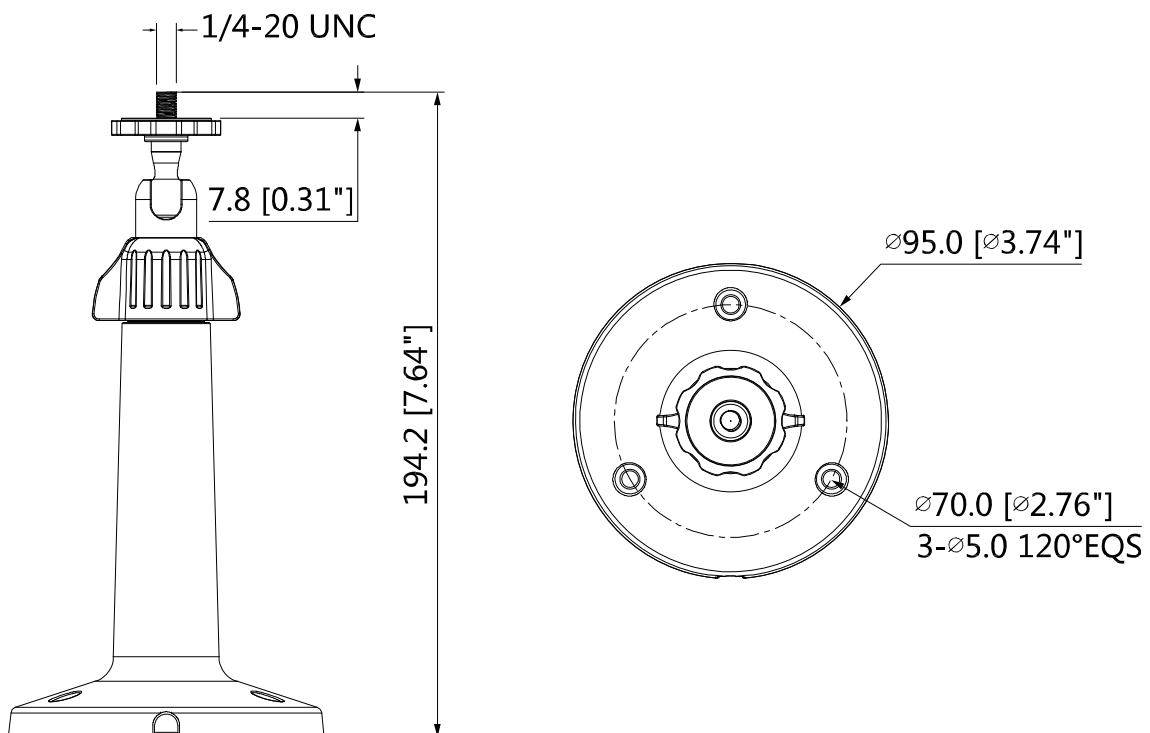

Application

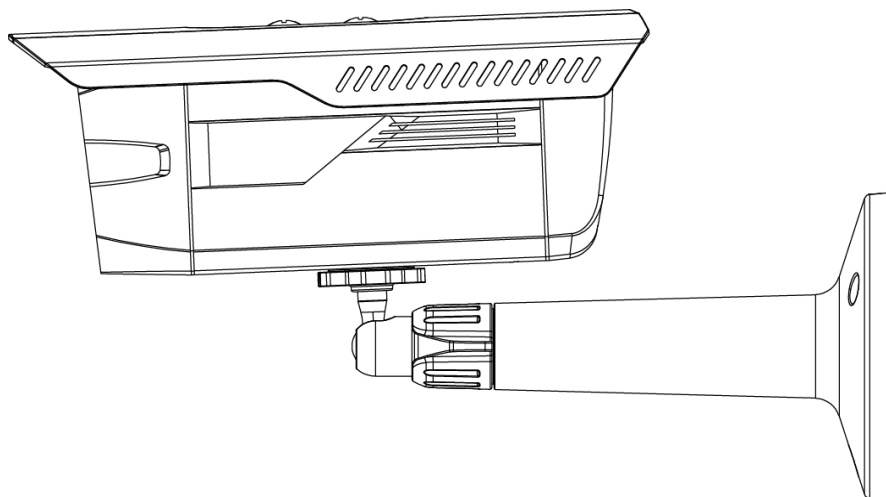

Package Information

- Wall mount bracket *1
- ST4 screw *3
- Plastic anchor *3