

DH-PFA134

Junction Box

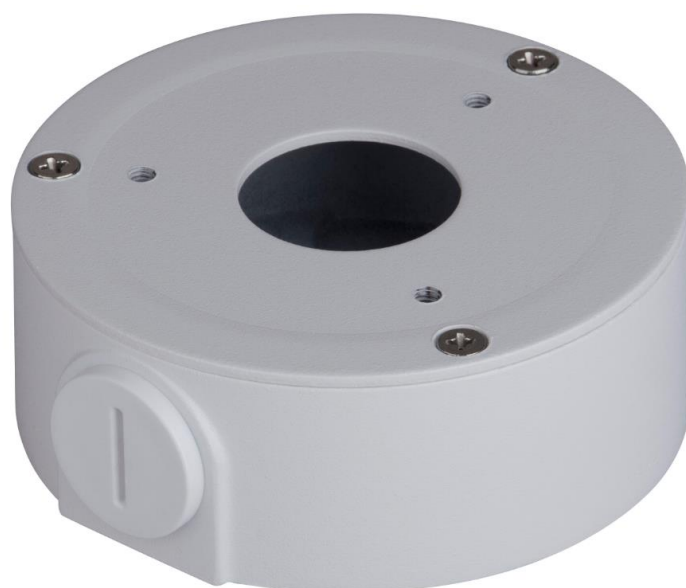

Features

- Aesthetic design
- Material: aluminum & SECC
- Junction box

Technical Specifications

Model	DH-PFA134
General	
Material	Aluminum & SECC
Dimension	Φ90.0mmx35.0mm (Φ3.54"x1.38")
Inch Thread	M20(G1/2")
Load Bearing	1.0kg(2.2lb)
Weight	0.26kg(0.57lb)
Color	White
Operating Temperature	-40°C ~ +60°C (-40°F ~ +140°F)
Humidity	0~90% RH
Applicable Model	Please see "Accessory Selection"

Order Information

Type	Part Number	Description
Camera Mount	DH-PFA134	Junction box
	PFA134	Junction box

Dimensions (mm/inch)

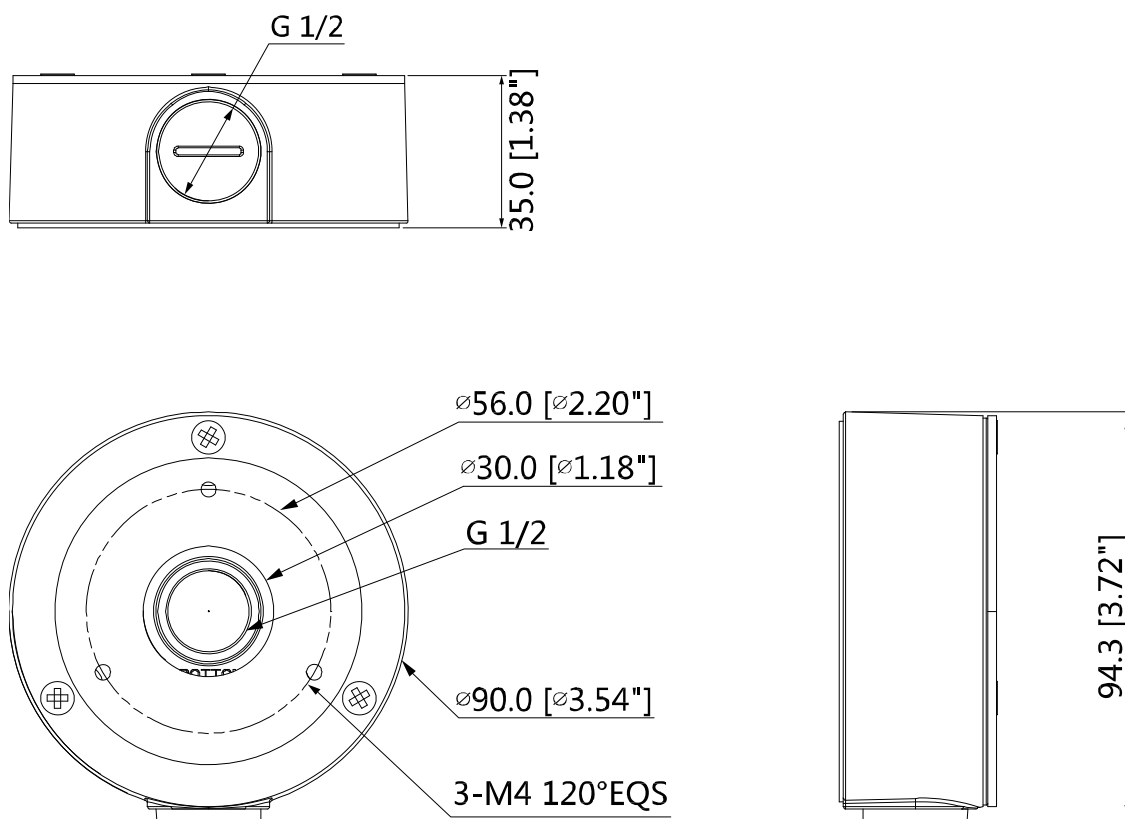

Application

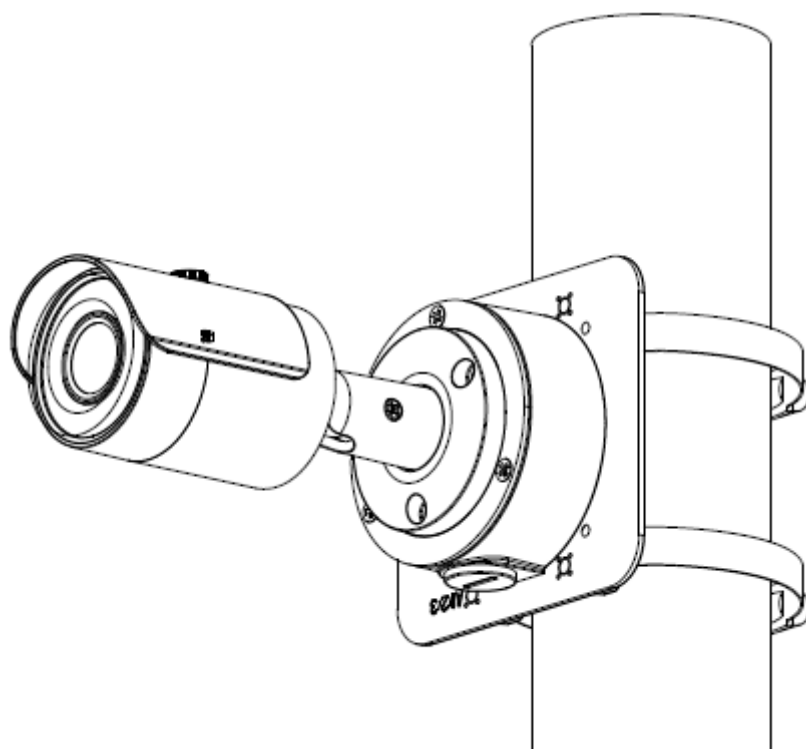

Package Information

- Junction box *1
- M4x10 screw *3
- ST4x25 screw *3
- Plastic anchor *3
- Water-proof joint *1
- Wrench *1