

DH-PFA130-E

Water-proof Junction Box



Features

- Neat & Integrated design
- Material: Aluminum
- IP66 junction box

Technical Specifications

| | |
|-----------------------|----------------------------------|
| Model | DH-PFA130-E |
| General | |
| Material | Aluminum |
| Dimension | Φ124mmx41mm(φ4.88"x1.61") |
| Pipe thread | G3/4" |
| Weight | 0.35kg(0.77lb) |
| Load bearing | 3.0kg(6.61lb) |
| Color | White |
| Protection | IP66 |
| Operating temperature | -40°C ~60°C(-40°F ~+140°F) |
| Humidity | <90% RH |
| Applicable model | Please see "Accessory Selection" |

Order Information

| Type | Part Number | Description |
|--------------|-------------|--------------------------|
| Camera mount | DH-PFA130-E | Water-proof junction box |
| | PFA130-E | Water-proof junction box |

Dimensions (mm/inch)

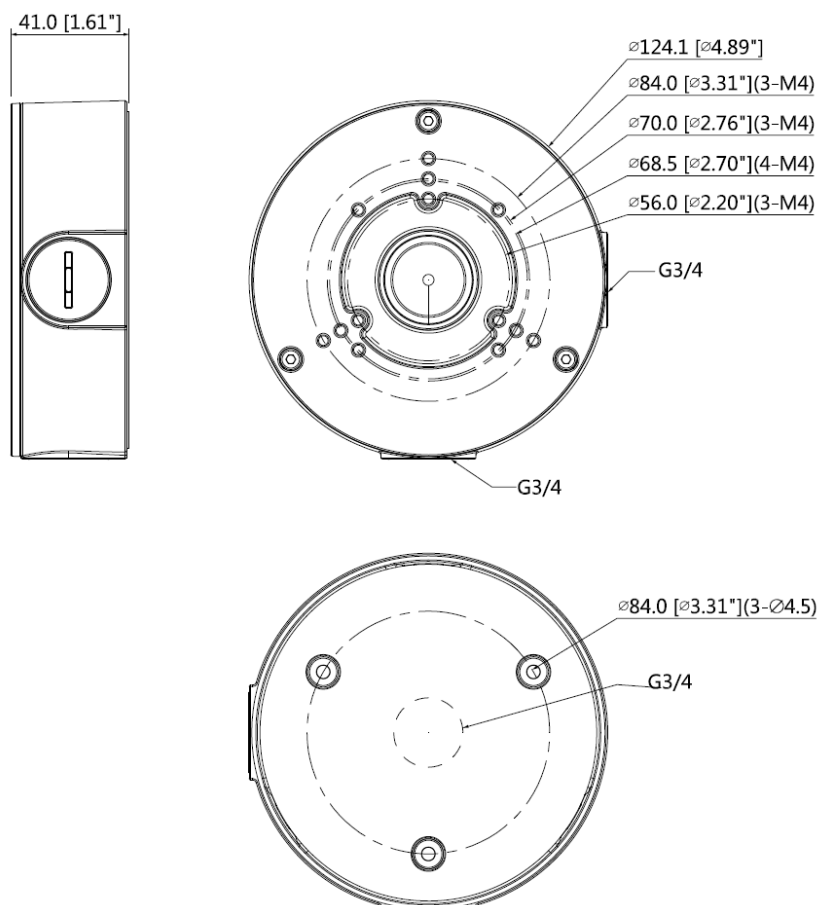

Application

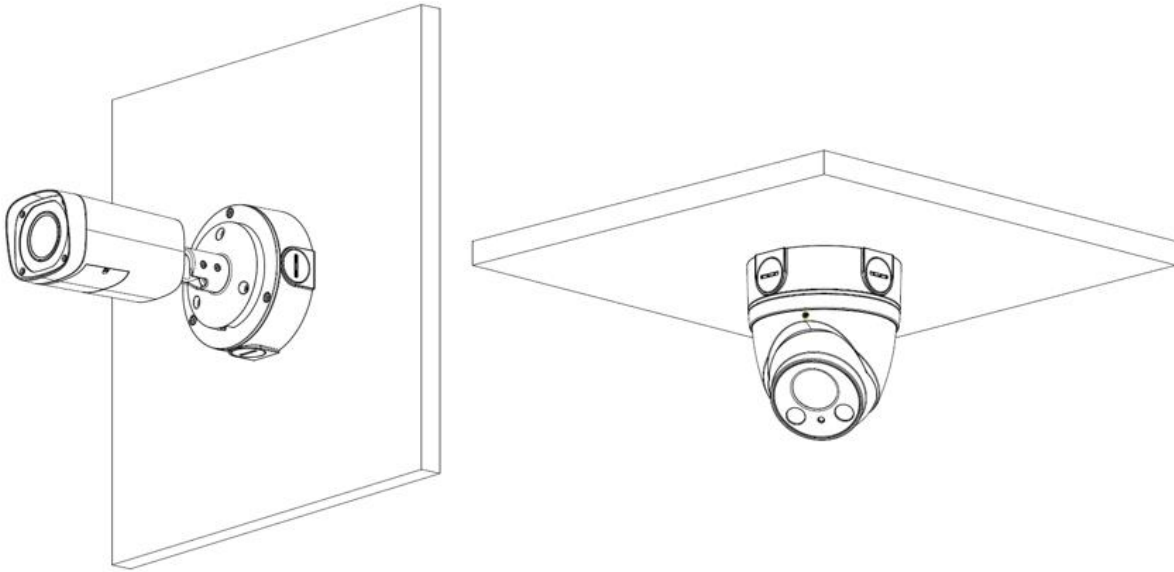

Package Information

- Water-proof junction box DH-PFA130-E *1
- M4x10 screw *4
- ST4.2x25 screw *3
- Plastic Anchor: 3
- Mounting sticker *1
- S3.0 wrench *1