

DH-PFA121

Water-proof Junction Box



Features

- Aesthetic design
- Material: aluminum
- IP66 junction box

Technical Specifications

| | |
|-----------------------|--|
| Model | DH-PFA121 |
| General | |
| Material | Aluminum |
| Dimension (WxHxD) | 134.0mmx133.5mmx56.0mm (5.28"x5.25"x2.20") |
| Pipe Thread | G3/4" |
| Weight | 0.54kg(1.19lb) |
| Load Bearing | 3.0kg(6.61lb) |
| Color | White |
| Protection | IP66 |
| Operating Temperature | -40°C~+60°C(-40°F~+140°F) |
| Humidity | 0~90% RH |
| Applicable Model | Please see "Accessory Selection" |

Order Information

| Type | Part Number | Description |
|--------------|-------------|--------------------------|
| Camera Mount | DH-PFA121 | Water-proof junction box |
| | PFA121 | Water-proof junction box |

Dimensions (mm/inch)

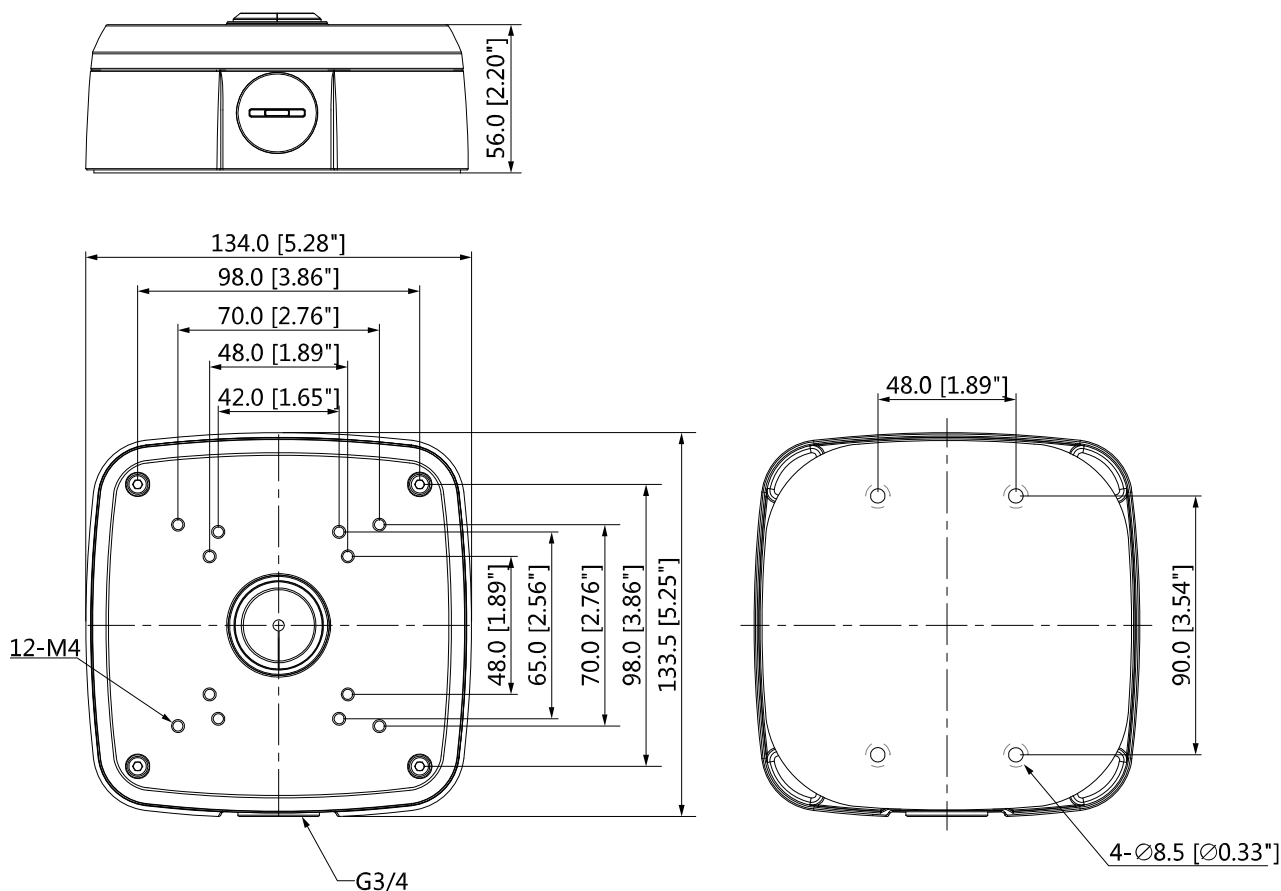

Application

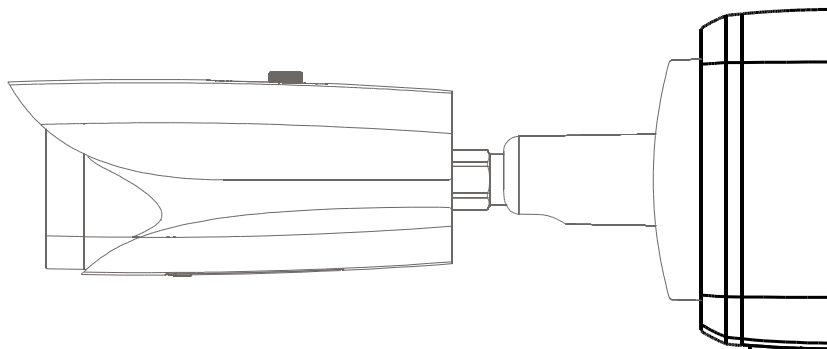

Package Information

- Water-proof junction box *1
- M4x10 screw *4
- ST6 screw *4
- Plastic anchor *4
- S3.0 wrench *1