

DH-SD42212T-HN

2MP 12x PTZ Network Camera



- 1/2.7" 2Megapixel CMOS
- Powerful 12x optical zoom
- Support Triple-streams encoding
- Max. 25/30fps@1080P, 25/30/50/60fps@720P
- IVS
- Support PoE+
- IP66, IK10



System Overview

Lite series is a range of attractively priced mini PTZ dome camera with compact design. The series is ideal for entry level applications, comprises outdoor and indoor cameras that are esthetically designed to blend in with a building. With pan at speeds of up to 400°/s, and tilt at speeds of up to 200°/s, the lite series ensures complete and timely video capture across a large area. It offers industry-leading IR capability of up to 100m, and IP66 and IK10 protection ratings. They are perfect for remote monitoring of applications such as airports, stores, banks, hotels, office lobbies and etc.

Functions

Wide Dynamic Range

The camera achieves vivid images, even in the most intense contrast lighting conditions, using industry-leading wide dynamic range (WDR) technology. For applications with both bright and low lighting conditions that change quickly, True WDR (120 dB) optimizes both the bright and dark areas of a scene at the same time to provide usable video.

Smart H.264+

Delivering high quality video without straining the network, Smart H.264+ is the optimized implementation of H.264. The Smart H.264+ encoding platform includes a scene adaptive encoding strategy, dynamic GOP, dynamic ROI, flexible multi-frame reference structure and intelligent noise reduction, providing a savings of up to 70% of bandwidth and storage when compared with standard H.264.

Environmental

Dahua cameras operate in extreme temperature environments, rated for use in temperatures from -30 °C to +60 °C (-22 °F to +140°F) with 95% humidity. The camera complies with the IK10 Vandal Resistance impact rating making it capable of withstanding the equivalent of 55 kg (120 lbs) of force. Subjected and certified to rigorous dust and water immersion tests, the IP66 rating makes it suitable for demanding outdoor applications.

Protection

The camera allows for ±10% input voltage tolerance, suitable for the unstable conditions for outdoor applications. Its 2KV lightning rating provides effective protection for both the camera and its structure against lightning.

Interoperability

The camera conforms to the ONVIF (Open Network Video Interface Forum) and PSIA (Physical Security Interoperability Alliance) specifications, ensuring interoperability between network video products regardless of manufacturer.

Technical Specification

Camera

Image Sensor	1/2.7" CMOS
Effective Pixels	1920(H) x 1080(V), 2 Megapixels
RAM/ROM	256M/128M
Scanning System	Progressive
Electronic Shutter Speed	1/1s~1/30,000s
Minimum Illumination	Color: 0.05Lux@F1.6; B/W: 0.005Lux@F1.6
S/N Ratio	More than 55dB
IR Distance	N/A
IR On/Off Control	N/A
IR LEDs	N/A

Lens

Focal Length	5.1mm~61.2mm
Max. Aperture	F1.6 ~ F3.0
Angle of View	H: 59.3° ~ 5.2°
Optical Zoom	12x
Focus Control	Auto/Manual
Close Focus Distance	100mm~ 1000mm

DORI Distance

*Note: The DORI distance is a "general proximity" of distance which makes it easy to pinpoint the right camera for your needs. The DORI distance is calculated based on sensor specification and lab test result according to EN 62676-4 which defines the criteria for Detect, Observe, Recognize and Identify respectively.

Detect	Observe	Recognize	Identify
883m(2897ft)	353m(1158ft)	177m(581ft)	88m(289ft)

PTZ

Pan/Tilt Range	Pan: 0° ~ 360° endless; Tilt: -2° ~ 90°, auto flip 180°
Manual Control Speed	Pan: 0.1° ~ 300° /s; Tilt: 0.1° ~ 120° /s
Preset Speed	Pan: 300° /s; Tilt: 200° /s
Presets	300
PTZ Mode	5 Pattern, 8 Tour, Auto Pan ,Auto Scan
Speed Setup	Human-oriented focal Length/ speed adaptation
Power up Action	Auto restore to previous PTZ and lens status after power failure
Idle Motion	Activate Preset/ Scan/ Tour/ Pattern if there is no command in the specified period
Protocol	DH-SD

Intelligence

Auto Tracking	N/A
IVS	Tripwire, Intrusion, Abandoned/Missing, Face Detection

Video

Compression	H.264+/H.264/MJPEG
Streaming Capability	3 Streams
Resolution	1080P(1920×1080)/720P(1280×720)/D1(704×576/704×480)/CIF(352×288/352×240)
Frame Rate	Main stream: 1080P/D1(1 ~ 25/30fps), 720P(1 ~ 50/60fps) Sub stream1: D1/CIF(1 ~ 25/30fps) Sub stream2: 720P/D1/CIF(1 ~ 25/30fps)
Bit Rate Control	CBR/VBR
Bit Rate	H.264+/H.264: 448K ~ 8192Kbps, MJPEG: 5120K ~ 10240Kbps
Day/Night	Auto(ICR) / Color / B/W
Backlight Compensation	BLC / HLC / WDR(120dB)
White Balance	Auto,ATW,Indoor,Outdoor,Manual
Gain Control	Auto / Manual
Noise Reduction	Ultra DNR (2D/3D)
Motion Detetion	Support
Region of Interest	Support
Electronic Image Stabilization (EIS)	N/A
Defog	Support
Digital Zoom	16x
Flip	180°
Privacy Masking	Up to 24 areas

Audio

Compression	G.711a/G.711mu/PCM
-------------	--------------------

Network

Ethernet	RJ-45 (10Base-T/100Base-TX)
Protocol	IPv4/IPv6,HTTP,HTTPS,SSL,TCP/IP, UDP,UPnP, ICMP,IGMP,SNMP,RTSP,RTP, SMTP, NTP,DHCP, DNS,PPPOE,DDNS,FTP, IP Filter,QoS,Bonjour,802.1x
Interoperability	ONVIF, PSIA, CGI
Streaming Method	Unicast / Multicast
Max. User Access	20 users
Edge Storage	NAS (Network Attached Storage),Local PC for instant recording, Micro SD card 128GB
Web Viewer	IE, Chrome, Firefox, Safari
Management Software	Smart PSS, DSS
Smart Phone	IOS, Android

Certifications

Certifications	CE: EN55032/EN55024/EN50130-4 FCC: Part15 subpartB,ANSI C63.4- 2014 UL: UL60950-1+CAN/CSA C22.2.No.60950-1
----------------	--

Interface

Video Interface	N/A
Audio Interface	1/1
RS485	N/A
Alarm I/O	2/1

Electrical

Power Supply	AC24V/1.5A(±10%), PoE+(802.3at)
Power Consumption	12W

Environmental

Operating Conditions	-30°C ~ 60°C (-22°F ~ +140°F) / Less than 90% RH
Ingress Protection	IP66
Vandal Resistance	IK10

Construction

Casing	Metal
Dimensions	Φ170(mm)×155(mm)
Net Weight	1.8kg(3.97lb)
Gross Weight	3.3kg(7.28lb)

Ordering Information

Type	Part Number	Description
2MP PTZ Camera	DH-SD42212T-HN	2MP 12x PTZ Network Camera, WDR, PAL
	DH-SD42212TN-HN	2MP 12x PTZ Network Camera, WDR, NTSC
	SD42212T-HN	2MP 12x PTZ Network Camera, WDR, PAL
	SD42212TN-HN	2MP 12x PTZ Network Camera, WDR, NTSC
Accessories	PFB302S	Wall Mount
	PFA102	Mount Adapter
	AC24V/1.5A	Power Supply
	PFB300C	Ceiling Mount
	PFA150	Pole Mount
	PFA151	Corner Mount

Accessories

Included:



AC24V/1.5A Power Supply

Optional:



PFB302S Wall Mount



PFA102 Mount Adapter



PFB300C Ceiling Mount



PFA150 Pole Mount

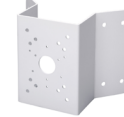

PFA151 Corner Mount

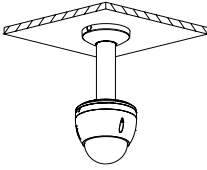
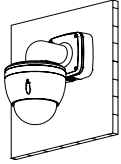
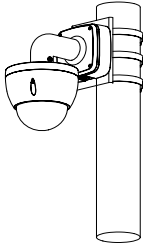
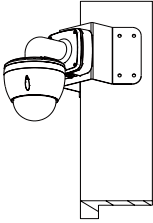
Ceiling Mount	Wall Mount
PFA102 + PFB300C	PFA102 + PFB302S
	
Pole Mount	Corner Mount
PFA102 + PFB302S + PFA150	PFA102 + PFB302S + PFA151
	

Dimensions (mm)

