

## DH-PFB602W

### Wall Mount Bracket



### Features

- Material: Aluminum
- Wall Mount Bracket
- Neat & Integrated design

### Specifications

Model	DH-PFB602W
<b>General</b>	
Material	Aluminum
Dimension (W x H x D)	109mm(W) x 300mm(H) x 82mm(D)
Pipe Thread	N/A
Operating Temperature	-40°C ~60°C
Humidity	0~90% RH
Load Bearing	3.0Kg
Weight	0.7kg
Applicable Model	PFH610N, PFH610N-IR, PFH610N-W, CA-FW480C, IPC-HFW3300, IPC-HFW5-IRA

# DH-PFB602W

## Dimensions (mm)

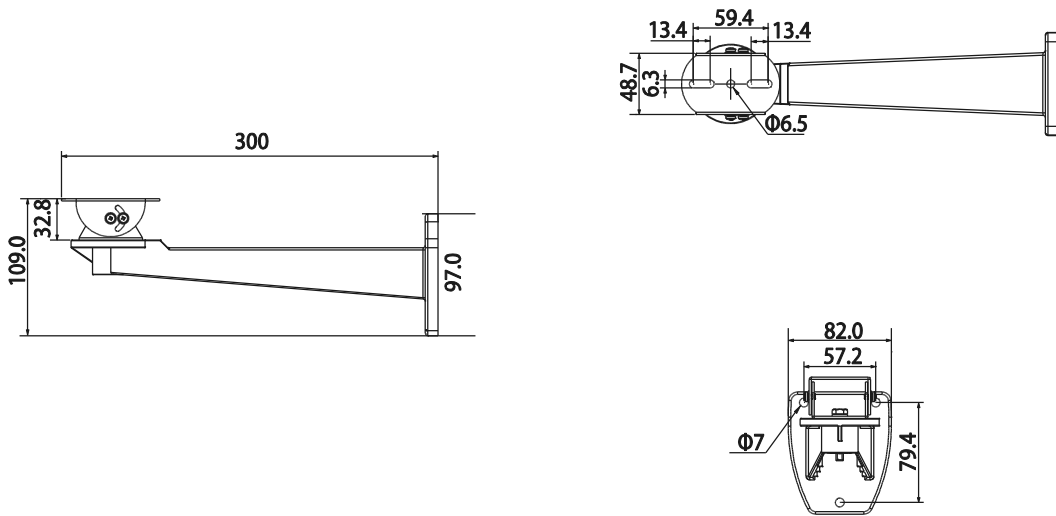

## Application

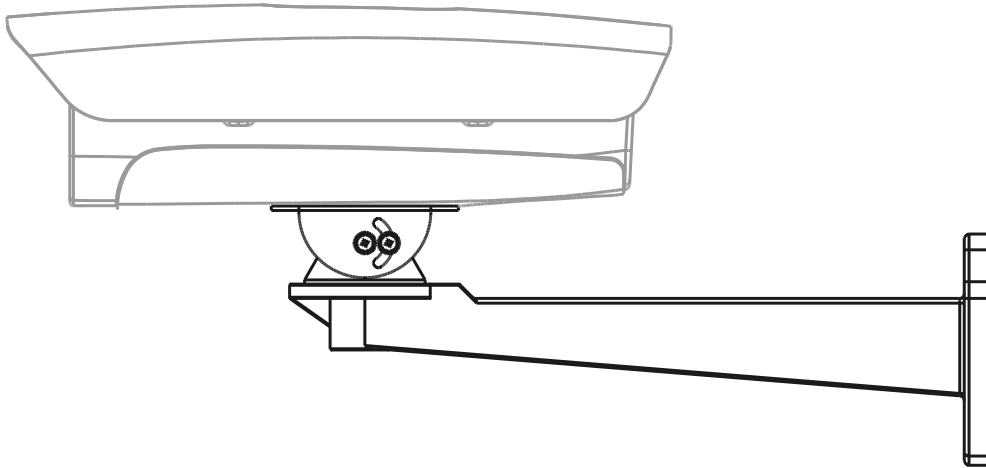

### Dahua Technology Co., Ltd.

1187 BinAn Road, Binjiang District, Hangzhou, China

Tel: +86-571-87688883

Fax: +86-571-87688815

Email: [overseas@dahuatech.com](mailto:overseas@dahuatech.com)

[www.dahuasecurity.com](http://www.dahuasecurity.com)

\*Design and specifications are subject to change without notice.

© 2013 Dahua Technology Co., Ltd.