

PFB601W

14" Housing Plane Mount Bracket



Features

- Material: Aluminum & PC
- Hidden line design
- Neat & Integrated design

Specifications

Model	PFB601W
General	
Material	Aluminum & PC
Dimension (W x H x D)	φ133.6mm x203.4mm
Pipe Thread	N/A
Operating Temperature	-40°C ~60°C
Humidity	0~90% RH
Load Bearing	3.0Kg
Weight	0.61Kg
Applicable Model	Please see "Accessory Selection"

PFB601W

Dimensions (mm)

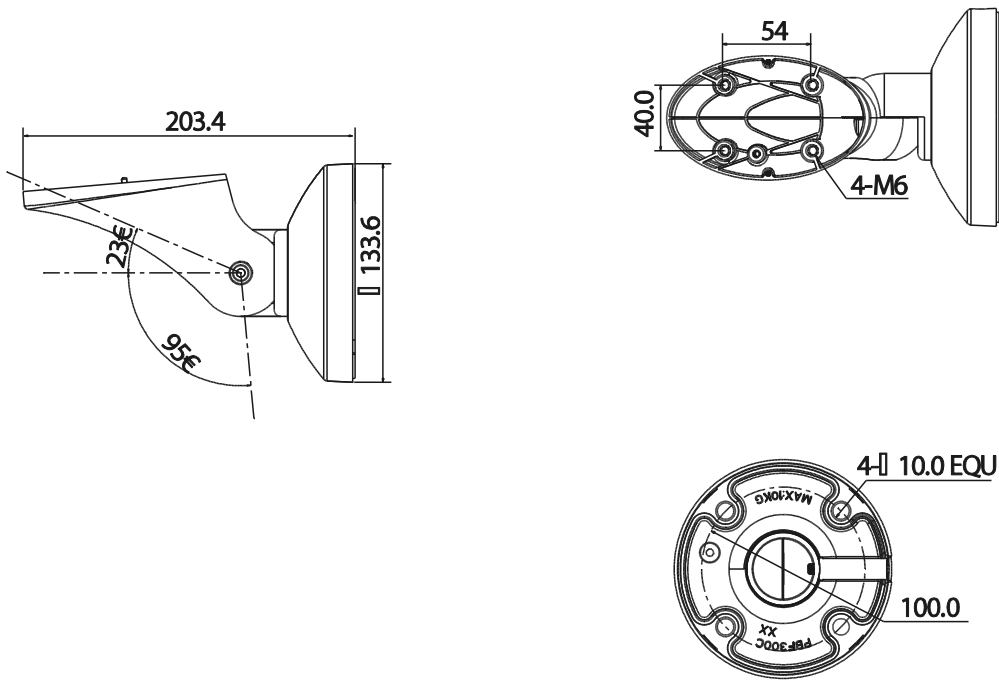

Application

