

DH-PFB303W-SG

Wall Mount Bracket

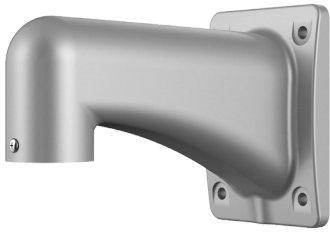

- Aluminum alloy material
- Matched with particular cameras, beautiful and elegant designed



Scene

Suitable for camera mounting with operating temperature from -40°C to $+60^{\circ}\text{C}$ (-40°F to $+140^{\circ}\text{F}$) and relative humidity less than 90%.

Technical Specification

Performance

Model	DH-PFB303W-SG
Material	Aluminum alloy
Dimensions	255.0 mm × 115.0 mm × 160.0 mm (10.04" × 4.53" × 6.30") (L × W × H)
Net Weight	0.66 kg (1.46 lb)
Load Bearing	7.0 kg (15.43 lb)
Operating Temperature	-40°C to $+60^{\circ}\text{C}$ (-40°F to $+140^{\circ}\text{F}$)
Operating Humidity	<90% (RH)
Color	Silver gray
Applicable Camera	Please see "Accessory Selection"

Ordering Information

Type	Model	Description
Camera Mount	DH-PFB303W-SG	Wall Mount Bracket

Installation

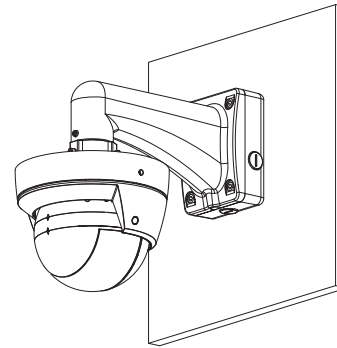

Dimensions (mm/inch)

